

FCC Statement:

This equipment has been tested and found to comply with the limits for a Class B digital device, pursuant to part 15 of the FCC Rules. These limits are designed to provide reasonable protection against harmful interference in a residential installation. This equipment generates, uses and can radiate radio frequency energy, and, if not installed and used in accordance with the instructions, may cause harmful interference to radio communications. However, there is no guarantee that interference will not occur in a particular installation. If this equipment does cause harmful interference to radio or television reception, which can be determined by turning the equipment off and on, the user is encouraged to try to correct the interference by one or more of the following measures:

- Reorient or relocate the receiving antenna.
- Increase the separation between the equipment and receiver.
- Consult the dealer or an experienced radio/TV technician for help.

CAUTION: Changes or modifications not expressly approved by the party responsible for compliance could void the user's authority to operate the equipment.

 **x3** 1.5V AA/R6 size  
**BATTERIES REQUIRED**  
 Alkaline batteries recommended.  
 Phillips/cross head screwdriver (not included) needed to insert batteries.

 **WARNING:**  
 CHOKING HAZARD-Small parts.  
 Not for children under 3 years.

**AGES 4+**  
 87591/87636 Asst.

**STAR  
 WARS**

**Millennium Falcon™**

Some assembly required.

THE LEGACY COLLECTION



Product and colors may vary.  
 © 2007 Lucasfilm Ltd. & © or TM where indicated. All rights reserved.  
 ®\* and/or TM\* & © 2007 Hasbro. All Rights Reserved.  
 TM & © denote U.S. Trademarks.



Not suitable for children  
 under 3 years because of  
 small parts - choking hazard.

P/N 6819130000

# ASSEMBLY

## BATTERIES

## EXTERIOR FEATURES

## INTERIOR FEATURES

Attach landing gear as shown, noting right and left positioning.

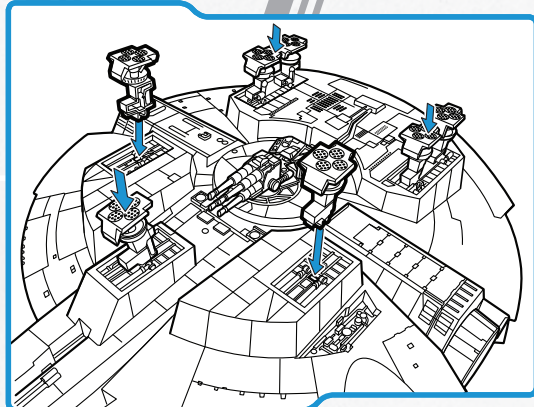

Attach laser cannons to top and bottom of vehicle.

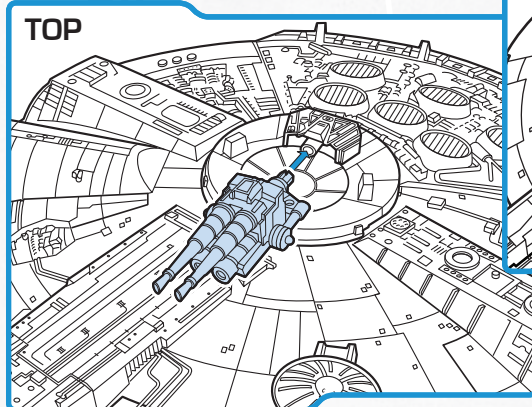

**BOTTOM**

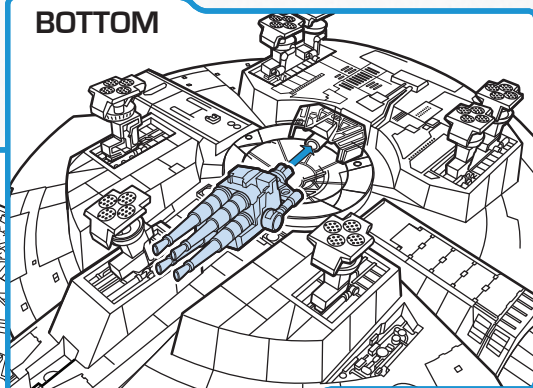

Attach laser cannon.

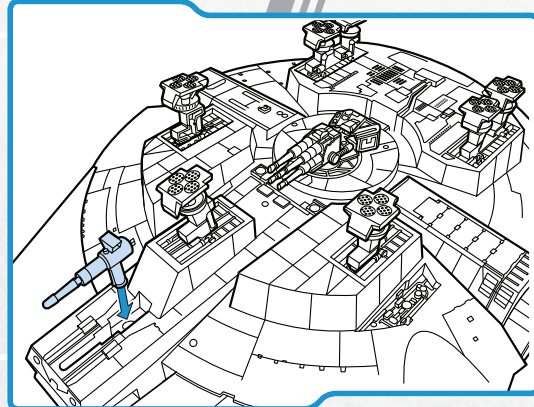

Attach sensor dish.

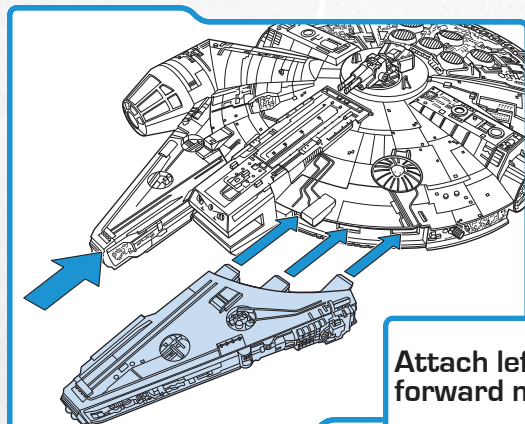
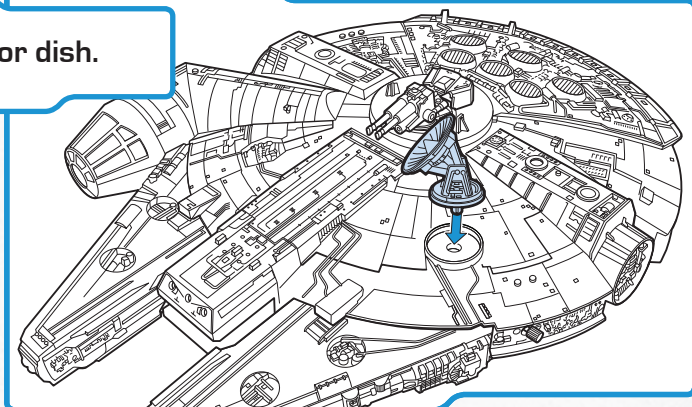

Attach left and right forward mandibles.

**NOTE:** These are a one-time fit; please make sure you are attaching them correctly – refer to illustration.

Peel and apply labels as shown. To access interior, remove panels (see page 8). For location names and visual references, see pages 9-10.

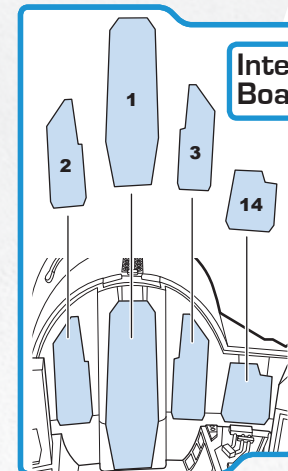
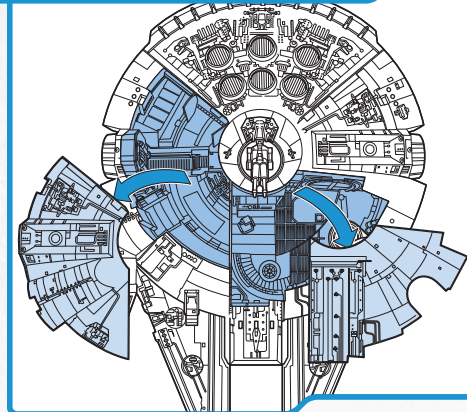

Interior - Near Boarding Ramp

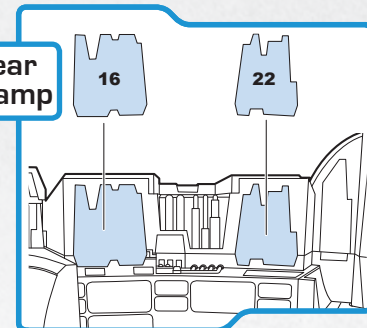

Training Probe Area - Underneath Laser Cannon

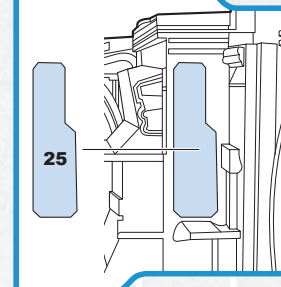

Cockpit Canopy Interior

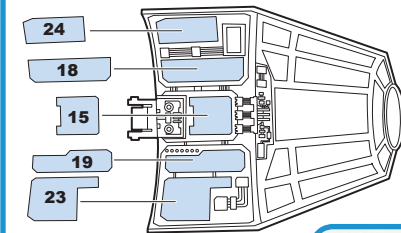

Cockpit Interior

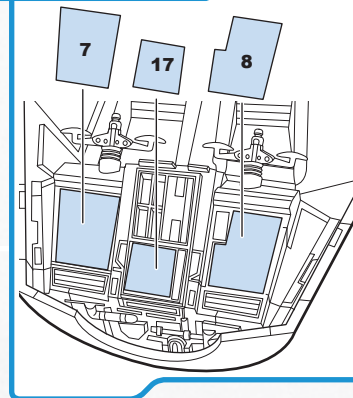

Mini-Fighter Interior

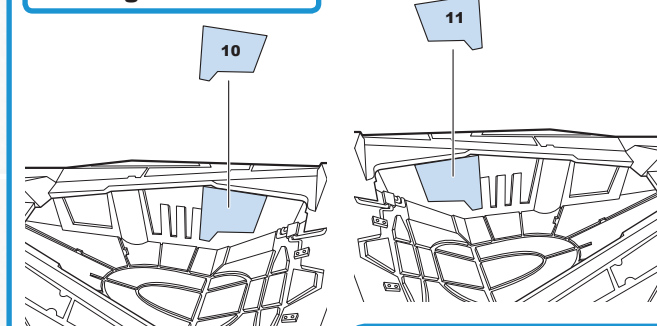

Medic Bay

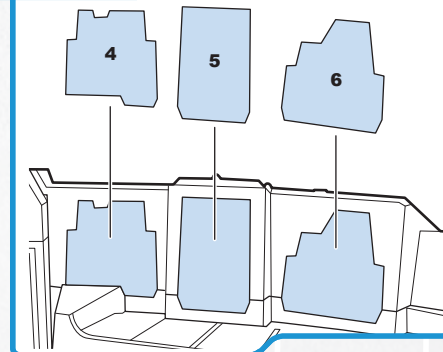

Cockpit Interior

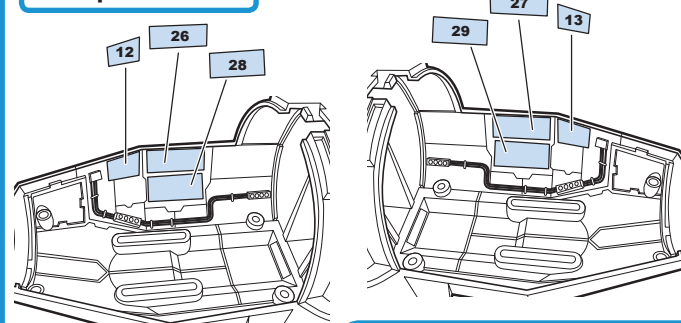

Under Satellite Dish

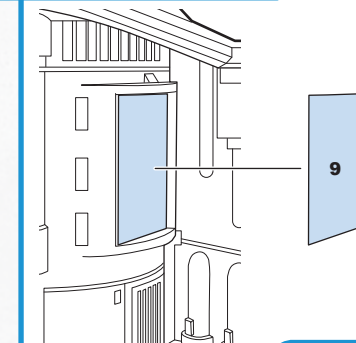

Training Probe Area

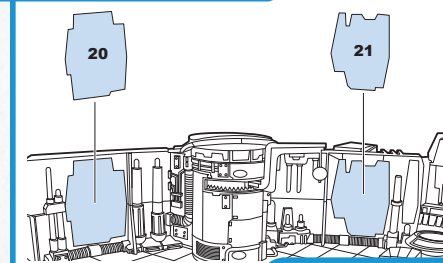

**TO INSERT BATTERIES:**

Squeeze hooks to remove cover. Using a Phillips/cross head screwdriver (not included), loosen screw in battery compartment door (screw remains attached to door). Remove door. Insert 3 x 1.5V "AA" or R6 size batteries (not included). Alkaline batteries recommended. Replace door and tighten screw. Replace cover

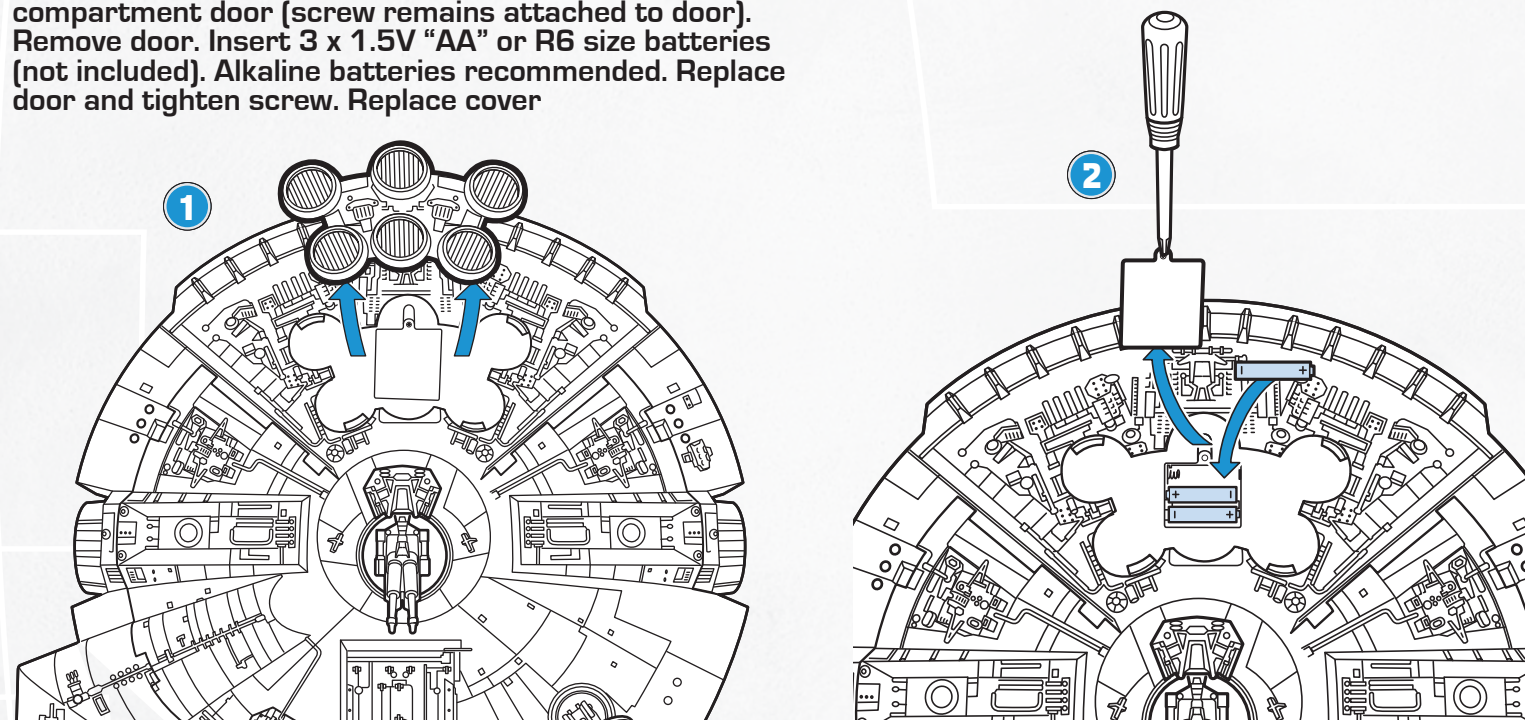

**CAUTION: TO AVOID BATTERY LEAKAGE**

1. Be sure to insert the batteries correctly and always follow the toy and battery manufacturers' instructions;
2. Do not mix old and new batteries or alkaline, standard (carbon-zinc) or rechargeable (nickel-cadmium) batteries;
3. Always remove weak or dead batteries from the product.

**IMPORTANT: BATTERY INFORMATION**

Please retain this information for future reference.  
Batteries should be replaced by an adult.

**CAUTION:**

1. Always follow the instructions carefully. Use only batteries specified and be sure to insert them correctly by matching the + and - polarity markings.
2. Do not mix old batteries and new batteries, or standard (carbon-zinc) with alkaline batteries.
3. Remove exhausted or dead batteries from the product.
4. Remove batteries if product is not to be played with for a long time.
5. Do not short-circuit the supply terminals.
6. Should this product cause, or be affected by, local electrical interference, move it away from other electrical equipment. Reset (switching off and back on again or removing and re-inserting batteries) if necessary.
7. RECHARGEABLE BATTERIES: Do not mix these with any other types of battery. Always remove from the product before recharging. Recharge batteries under adult supervision. DO NOT RECHARGE OTHER TYPES OF BATTERIES.

**Switch Activation:** The vehicle has 13 switches. For switches 1, 3, 5, and 6, press them for different time lengths to activate different features:  
Short-press = press/release quickly  
Long-press = press and hold, then release

**Switch #2**

**Laser cannon:** Insert missiles into cannon. Slide switch to rotate cannon and activate firing sounds. When cannon hits tabs, the missiles will automatically fire.

**Note:** Interchangeable projectiles will fit into all the working launchers on this vehicle.

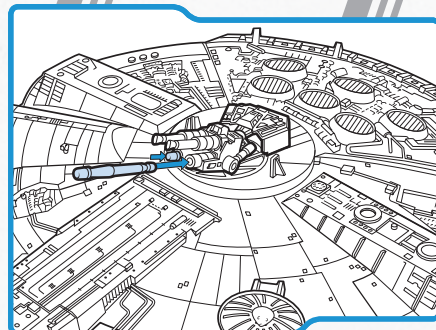
**Switch #13**

**On/Off:** Slide switch to "On" position. When finished playing with toy, slide switch to "off" position to help conserve battery life.

**Switch #1**

**Startup:** Short-press switch to activate startup sequence (lights, sounds). The sequence will randomly "fail," re-creating the *Falcon's* infamous "breakdowns" in the movies; if it "fails," short-press switch again to activate startup.

Long-press switch to hear these phrases:  
"She may not look like much, but she's got it where it counts, kid."  
"Chewie, get us out of here!"  
"What's that flashing?"  
"We're losing the deflector shield."  
"Go strap yourselves in; I'm going to make the jump to lightspeed."  
"You're all clear, kid."  
"Let's blow this thing and go home!"  
"Great shot, kid. That was one in a million."  
"Come on, come on! Switch over. Let's hope we don't have a burnout."

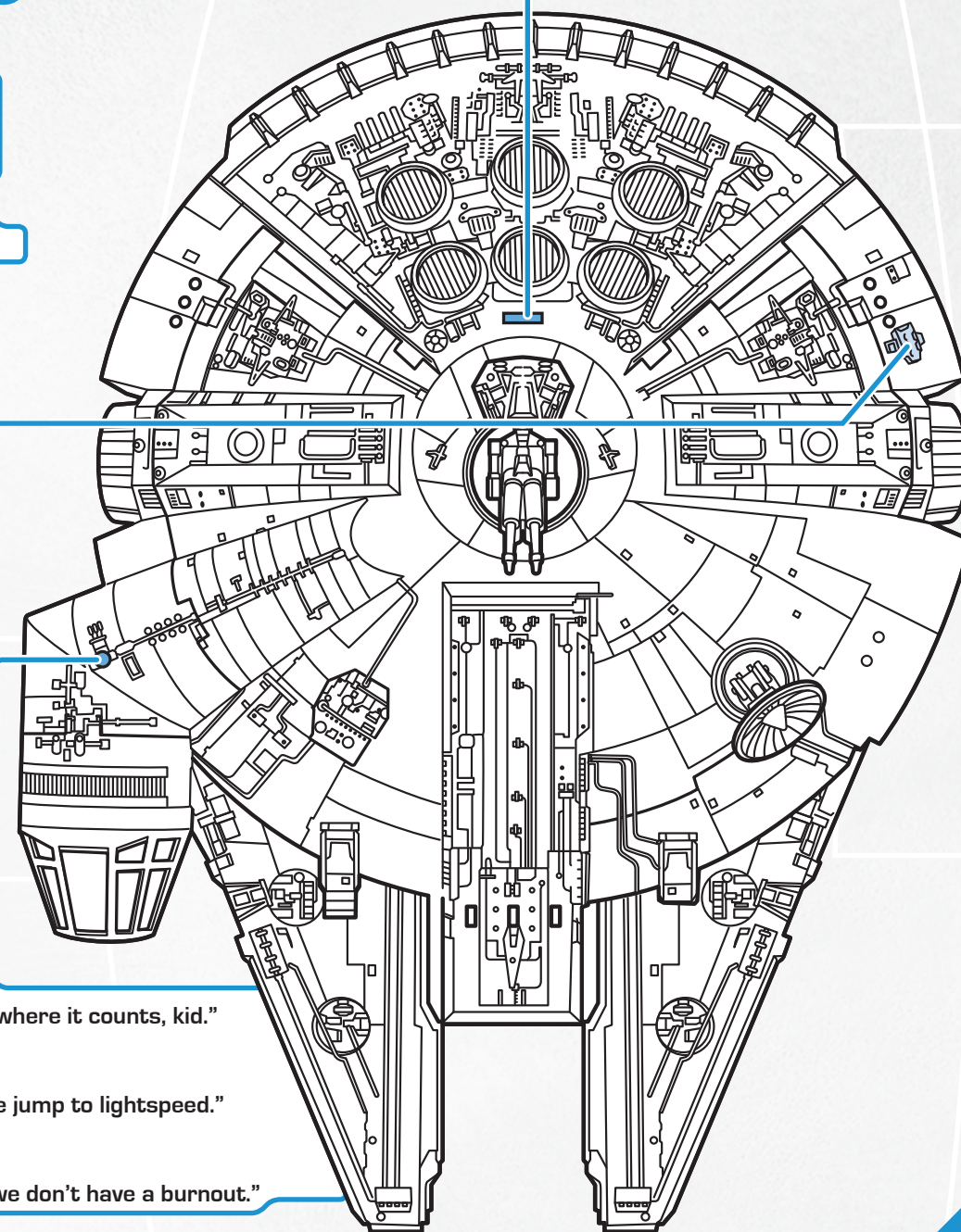

**Switch #8**  
Fly-by: If engine is on (already playing cruise sounds), pressing this switch will activate fly-by sound.

If engine is not on (if vehicle is switched on but Switch #1 Startup has not been pressed), pressing this switch will activate startup sequence (lights and sounds) and cruise sound.

**Switch #7**  
Boost/cruise: If engine is on (already playing cruise sounds), pressing the switch will activate boost sounds, engine lights and cruise sounds.

If engine is not on (if vehicle is switched on but Switch #1 Startup has not been pressed), pressing this switch will activate startup sequence (lights and sounds) and cruise sound.

**Switch #6**  
Battle sounds/dialogue: Short-press switch to hear cannon firing sounds.

Long-press switch to hear these phrases:  
"Hold them off. Angle the deflector shields while I charge up the main guns!"  
"Okay, stay sharp!"  
"Don't worry, she'll hold together."  
"Got him! I got him!"  
"Great kid, don't get cocky."  
"That's it! We did it!"

**Switch #9**  
Auto-open boarding ramp: Press switch - ramp will lower automatically accompanied by sounds and lights. To close, manually raise ramp until it latches in place.

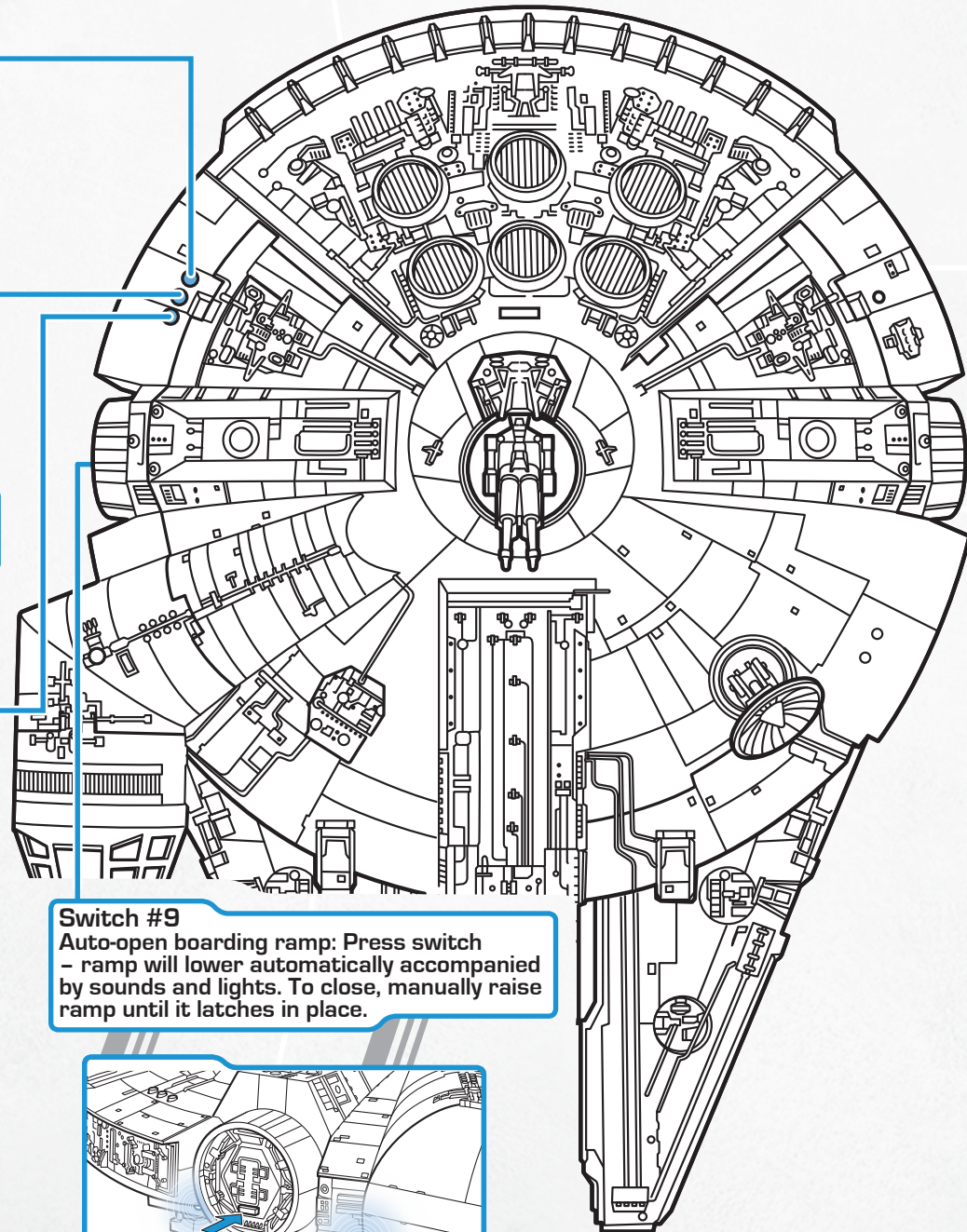
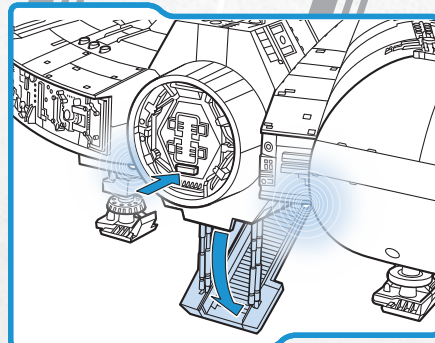

**Switches #11 & #12**  
Docking bay: These switches are automatically activated when you insert or remove the mini-fighter or close the hatch.

- Manually open hatch and place mini-fighter all the way inside bay to activate docking sounds.
- Close the hatch for hatch closing sounds.
- Open the hatch and remove the mini-fighter for escape sounds.

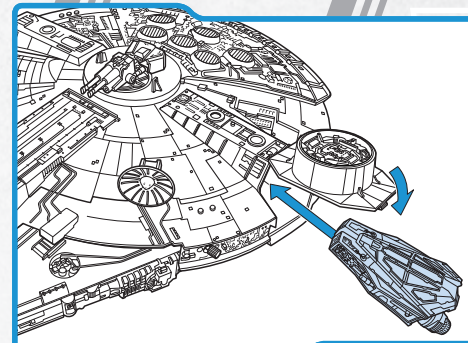

**Switch #10**  
Missiles: Insert missiles into launcher. Press button to fire center missile and hear firing sounds. Firing sounds will repeat each time you press the switch, even when no missile is in the launcher.

Press the other 2 buttons to fire remaining 2 missiles (they do not make sounds when fired).

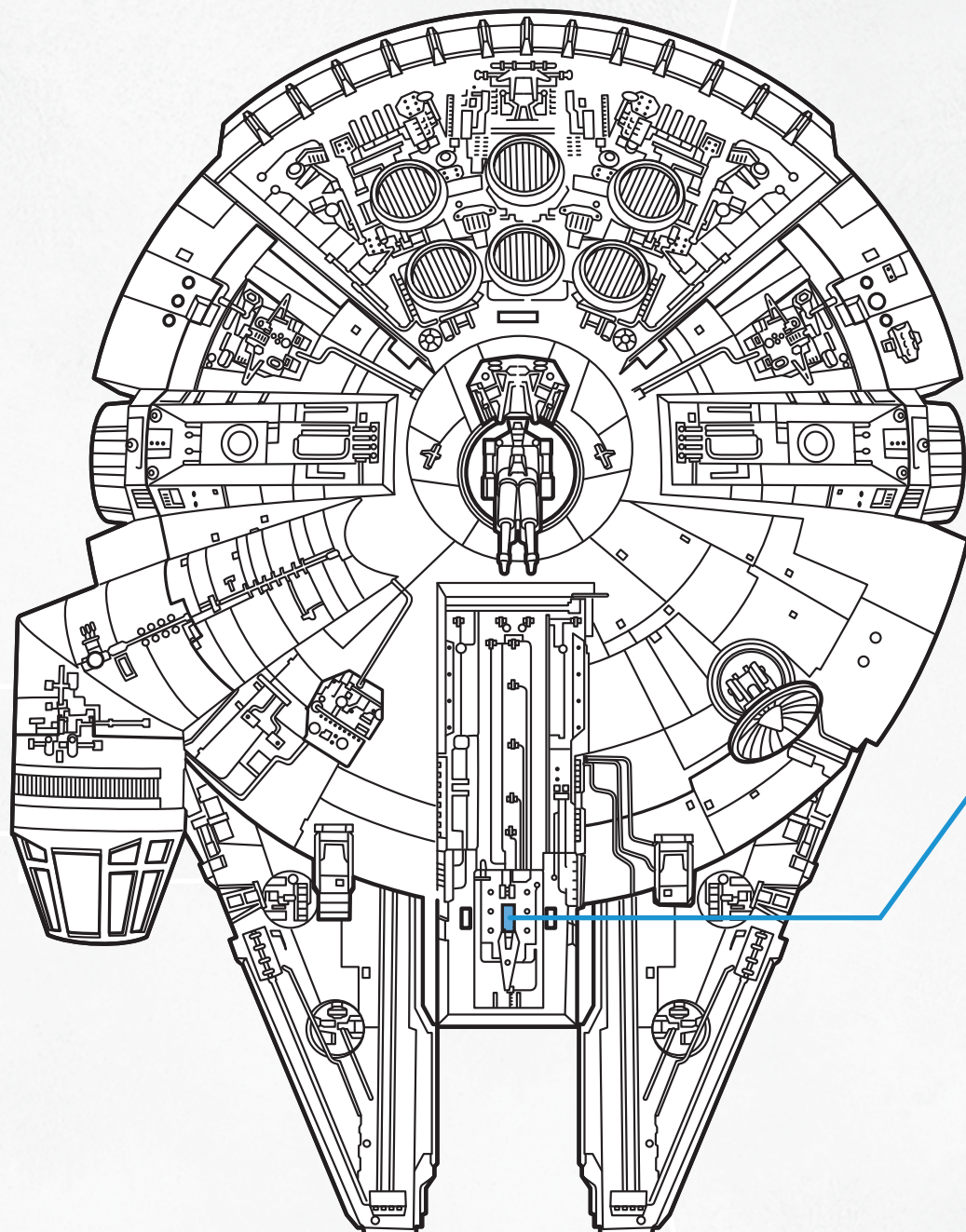
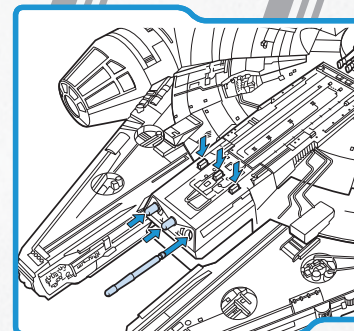

**Fighter:**  
Insert missile into launcher on mini-fighter and press button to fire.

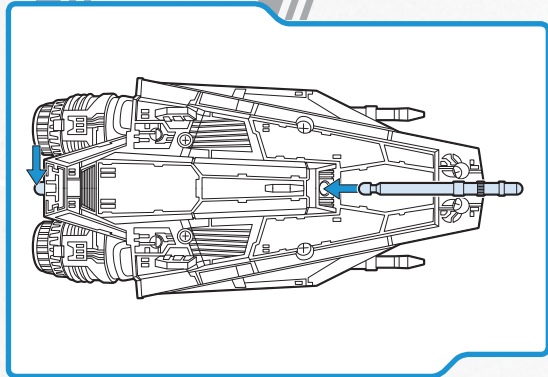

Slide button on either side of mini-fighter to make non-firing missiles extend and retract.

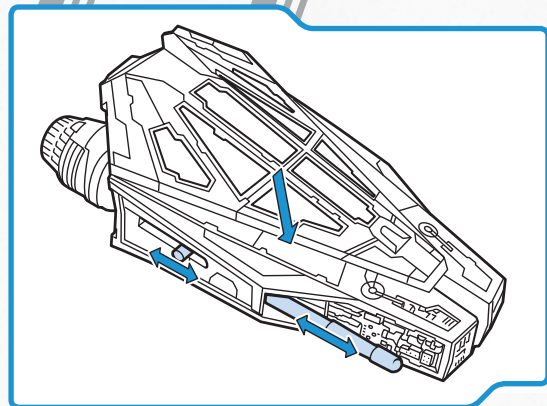

**Sensor dish:** Turn knob to rotate dish.

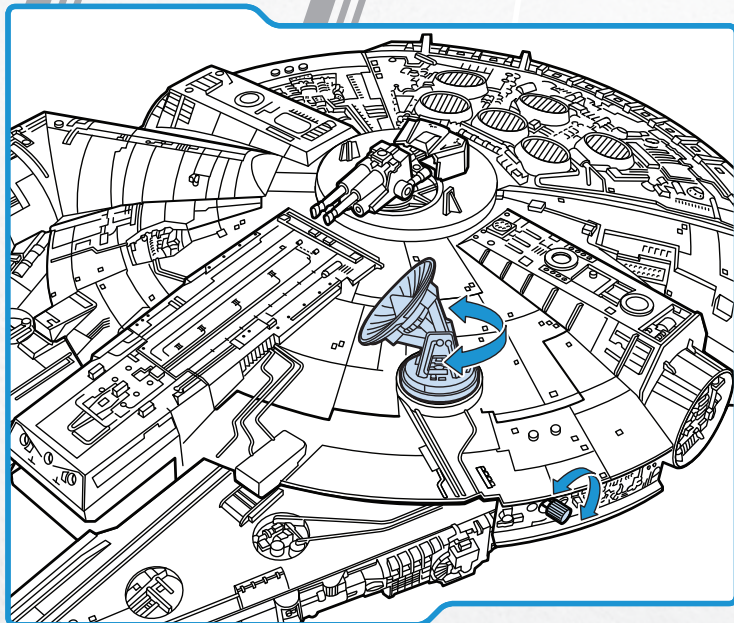

To access interior: Remove 2 covers on top of vehicle.

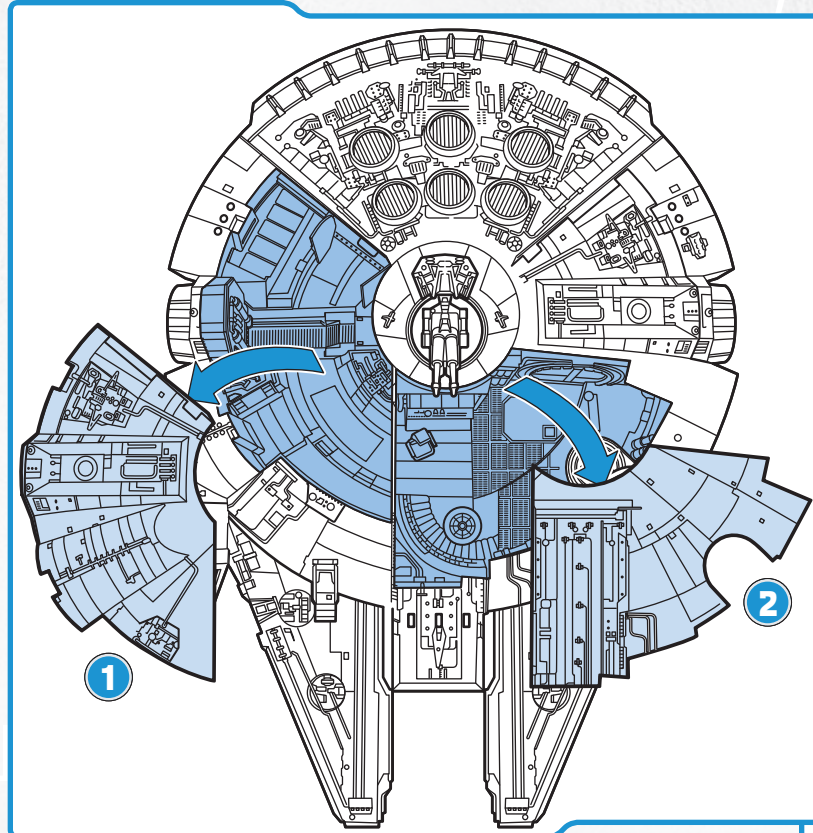

To replace covers, attach side A first, then side B.

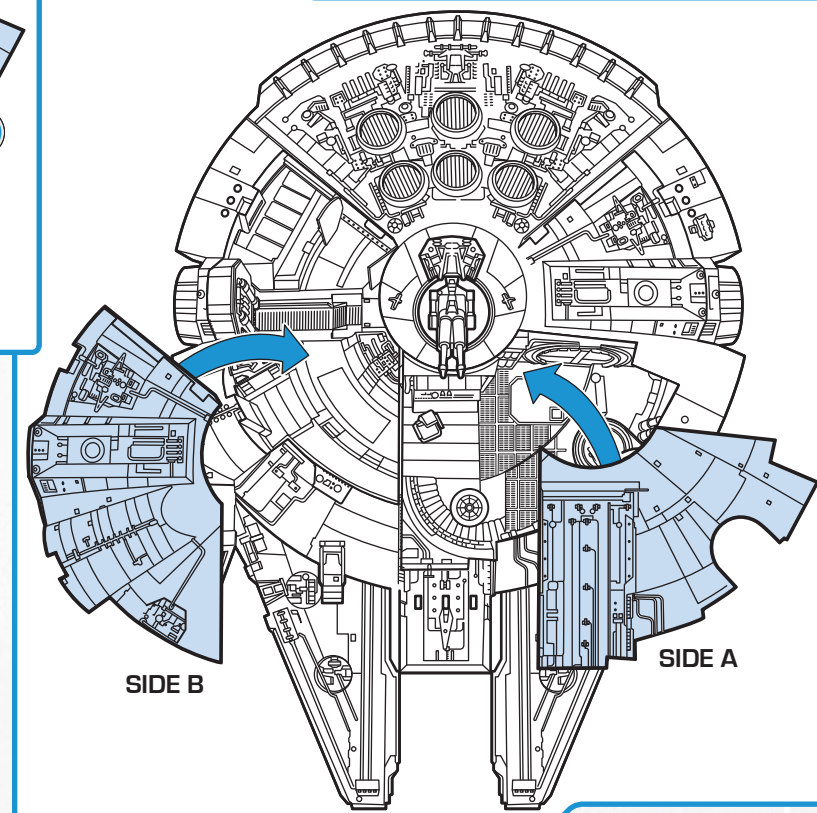

**Switch #3**

Dejarik table: Short-press switch to activate table light and hear a sound/phrase. Keep short-pressing the switch to cycle through the Wookiee sounds, R2-D2 sounds, and the following phrases: "It's not wise to upset a Wookiee." "I suggest a new strategy, Artoo: let the Wookiee win."

Long-press switch - all the sounds and phrases will play at once.

**Switch #5**

Training dialogue: Short-press switch to hear training sounds and the following phrases: "With the blast shield down, I can't even see. How am I supposed to fight?" "You see, you can do it." "You've taken your first step into a larger world."

Long-press to activate R2-D2 sounds, vehicle lights and sounds, and the following phrases: "Artoo, come back at once! You don't know how to fix the hyperdrive." "You did it!"

**Switch #4**

Training probe: Push knob in to activate training sounds. Turn knob to rotate arm and make probe move.

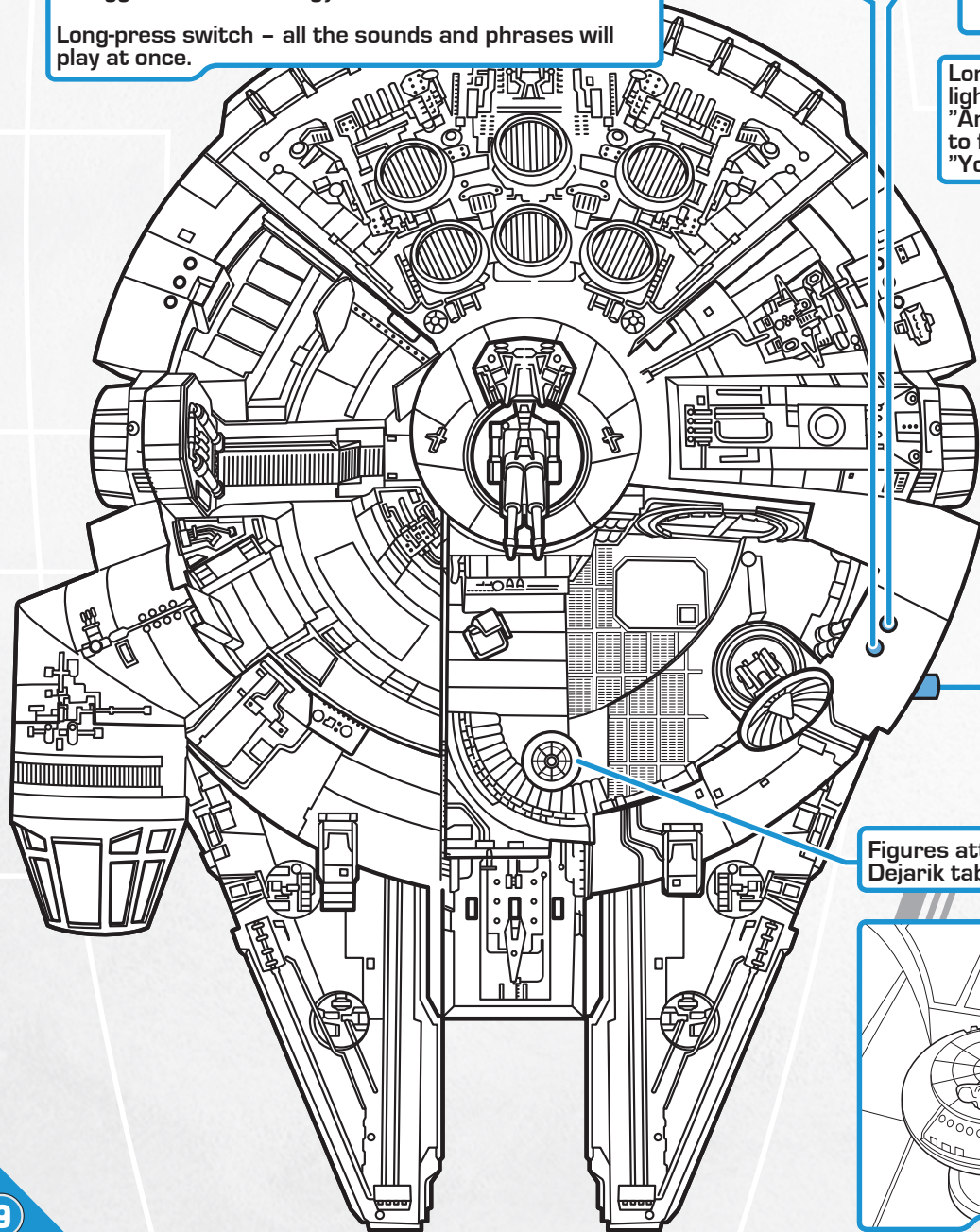

Figures attach to Dejarik table as shown.

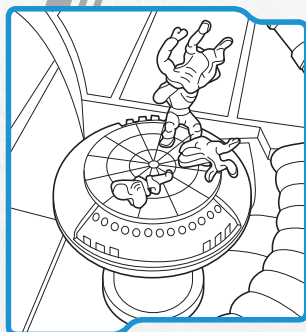

Assemble training remote as shown.

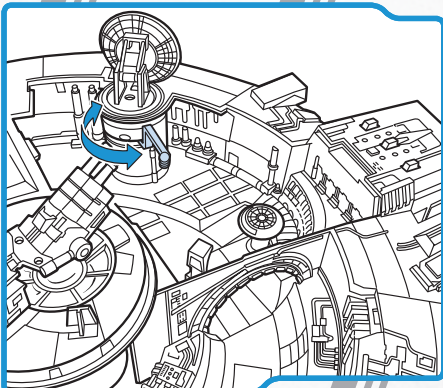
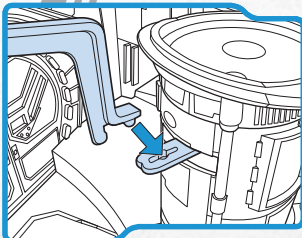

Cockpit: Manually lift cockpit; it can hold 4 figures (2 figures included; others sold separately). Front seats adjust forward and backward to accommodate different figures.

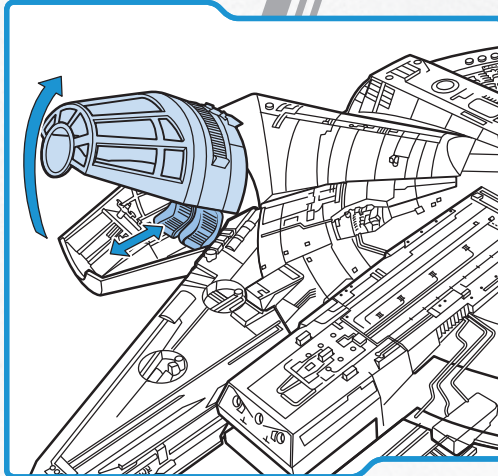

Smuggler's compartments: Lift panels in floor to reveal compartments.

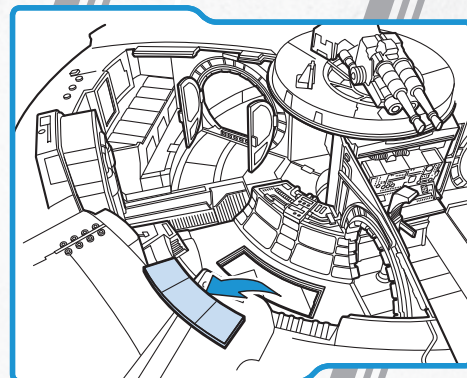

Doors: See illustration to locate doors "A" and "B" that open to reveal storage areas.

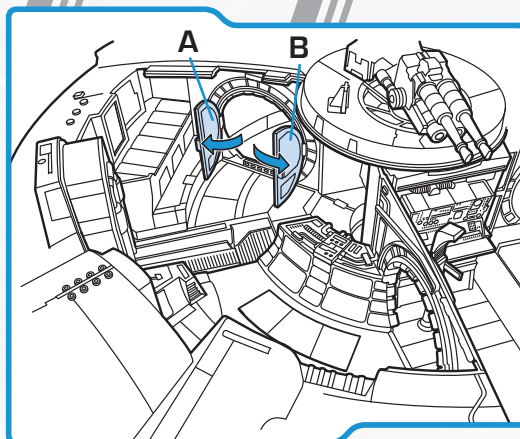

Medical Bay: Figure can be placed in bay.

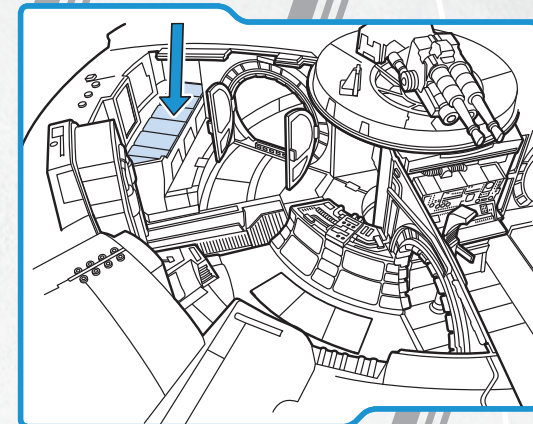

Storage bin can hold gas masks or other accessories (not included).

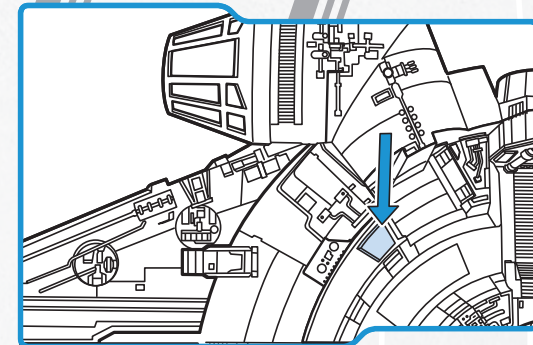

Laser cannon seat: Seat moves back and forth as turret moves.

